

LAB-MOBI

MULTI-CHANNEL BATTERY PACK CYCLER



POSITIVE PROBLEM SOLVING **+ =**

Bidirectional LAB-MOBI battery cyclers have 2 or 4 output channels with nominals up to 1000V/1000A. Each channel is programmable for charge/discharge cycles.

While each channel is independently controllable they share a common rectifier section. This saves cost when compared to separate bidirectional systems. Energy can be recycled between channels above the unit's nominal power. For example a 4 channel 500kW system can sink up to 1MW from a battery pack in the first channel, and use the energy directly in the second. The unit's remaining 500kW capability can still be used across the other 2 channels to and from the grid.

- + Seamless Transition Between Source/Sink**
- + Nominal Outputs up to 1000V/±1000A**
- + Power Recycling Between Channels**
- + Extremely Wide Operating Ranges**
- + Lowest Life Component 67,000h**
- + High Dynamics and Stability**

CONTENTS

Multi Channel Test Configurations	2
Two Channel Selection Table	3
Four Channel Selection Table	4
System Topology & Input	5
General Specifications	6
Output	7-10
Interfaces & Control	11-12
Isolation, Safety & Protection	13
Common LAB-MOBI Applications	14

MULTI CHANNEL TEST CONFIGURATIONS

The LAB-MOBI is an incredibly flexible power system which can be configured in a number of ways. Examples of the possible configurations are shown for the LAB-MOBI 1000-500-1000 systems. For other model specific diagrams contact ETPS Ltd.

TWO AND FOUR CHANNEL MODES

CONFIGURATION ONE - CHANNEL RECYCLING

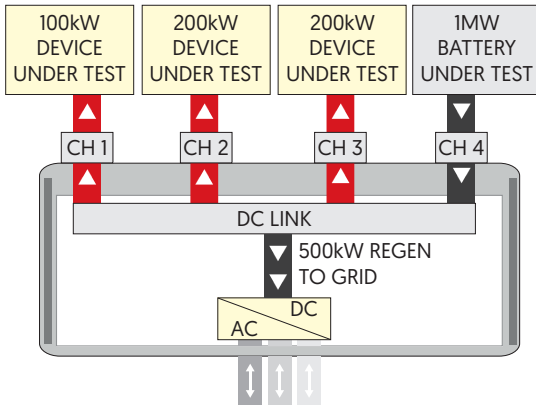

Energy can be recycled between channels above the system's nominal power. For example a 4 channel 500kW system can sink up to 1MW from a source, such as a battery pack, from channel four and use the energy directly across the other three channels. The unit's remaining capability can still be used across the other 3 channels to and from the grid. This feature is particularly useful for sites which have a limited incoming grid infrastructure.

While each individual channel is only able to sink or source its nominal current/voltage, higher currents can be achieved when operating channels in parallel configuration. For example a four channel 500kW/1000A system can sink or source currents up to 2000A when operating two channels in parallel and 4000A when combining four channels. Please note that the system's internal DC link is limited to 2MW.

CONFIGURATION TWO - ALL CHANNELS INDEPENDENT

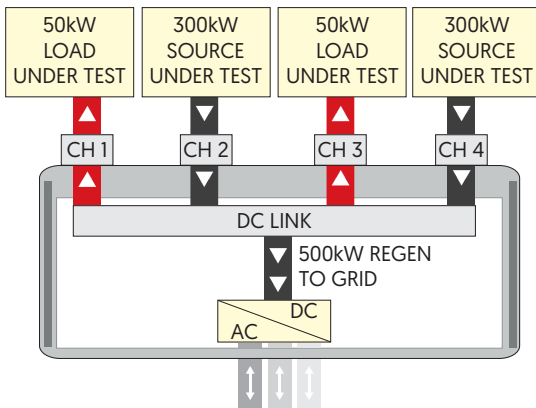

4 Channels: CH1, CH2, CH3 and CH4 in single operation.
2 Channels: CH1 and CH2 in single operation.

CONFIGURATION THREE - ALL CHANNELS IN PARALLEL

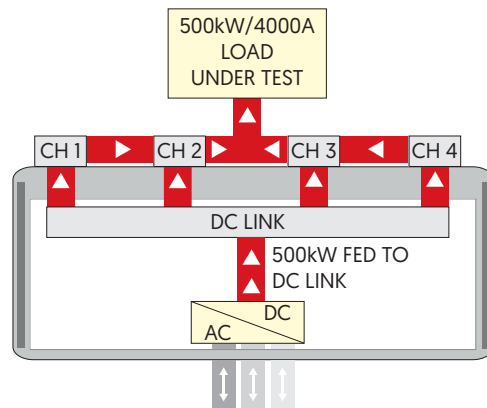

4 Channels: CH1, CH2, CH3 and CH4 in parallel operation.
2 Channels: CH1 and CH2 in parallel operation.

FOUR CHANNEL ONLY MODES

CONFIGURATION FOUR - 2 PAIRS OF PARALLEL CHANNELS

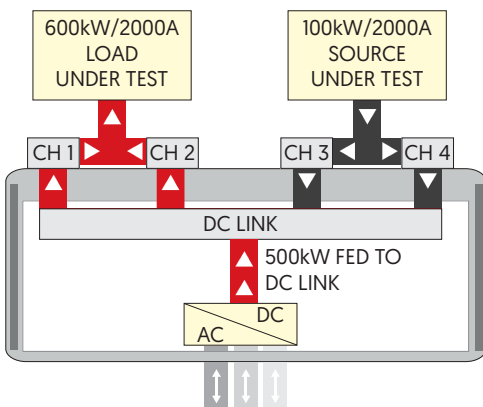

CH1 and CH2 in parallel operation. CH3 and CH4 in parallel operation.

CONFIGURATION FIVE - 2 INDEPENDENT, 2 PARALLEL

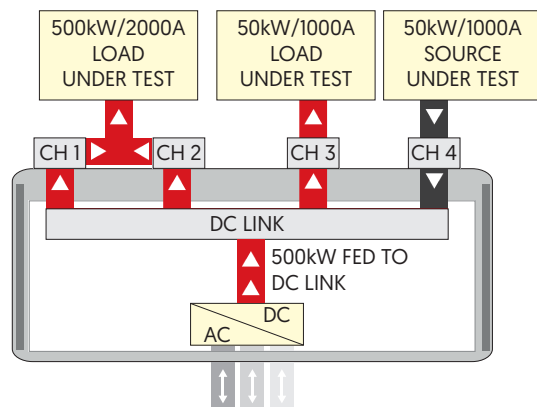

CH1 and CH2 in parallel operation. CH3 and CH4 in single operation

TWO CHANNEL MODEL SELECTION TABLE

Part Number	Max. Power	Q1 Source Voltage Range	Q4 Sink Voltage Range ¹	Current Range per Channel ²	Number of Channels	Internal Resistance Range - Single Channel	Internal Resistance Range - Channels Paralleled
60kW MODELS							
LAB-MOBI 300-60-200-2	60kW	0 - 300V	5 - 300V	0 ± 200A	2	-15mΩ to 1500mΩ	-15mΩ to 150mΩ
LAB-MOBI 300-60-600-2	60kW	0 - 300V	5 - 300V	0 ± 600A	2	-5mΩ to 500mΩ	-5mΩ to 50mΩ
LAB-MOBI 600-60-200-2	60kW	0 - 600V	5 - 600V	0 ± 200A	2	-30mΩ to 3000mΩ	-30mΩ to 300mΩ
100kW MODELS							
LAB-MOBI 600-100-200-2	100kW	0 - 600V	5 - 600V	0 ± 200A	2	-30mΩ to 3000mΩ	-30mΩ to 300mΩ
LAB-MOBI 600-100-600-2	100kW	0 - 600V	5 - 600V	0 ± 600A	2	-10mΩ to 1000mΩ	-10mΩ to 100mΩ
LAB-MOBI 800-100-200-2	100kW	0 - 800V	5 - 800V	0 ± 200A	2	-40mΩ to 4000mΩ	-40mΩ to 400mΩ
LAB-MOBI 1000-100-200-2	100kW	0 - 1000V	5 - 1000V	0 ± 200A	2	-50mΩ to 5000mΩ	-50mΩ to 500mΩ
120kW MODELS							
LAB-MOBI 300-120-200-2	120kW	0 - 300V	5 - 300V	0 ± 200A	2	-15mΩ to 1500mΩ	-15mΩ to 150mΩ
LAB-MOBI 300-120-600-2	120kW	0 - 300V	5 - 300V	0 ± 600A	2	-5mΩ to 500mΩ	-5mΩ to 50mΩ
LAB-MOBI 300-120-1000-2	120kW	0 - 300V	5 - 300V	0 ± 1000A	2	-3mΩ to 300mΩ	-3mΩ to 30mΩ
160kW MODELS							
LAB-MOBI 300-160-200-2	160kW	0 - 300V	5 - 300V	0 ± 200A	2	-15mΩ to 1500mΩ	-15mΩ to 150mΩ
LAB-MOBI 300-160-600-2	160kW	0 - 300V	5 - 300V	0 ± 600A	2	-5mΩ to 500mΩ	-5mΩ to 50mΩ
LAB-MOBI 300-160-1000-2	160kW	0 - 300V	5 - 300V	0 ± 1000A	2	-3mΩ to 300mΩ	-3mΩ to 30mΩ
LAB-MOBI 600-160-200-2	160kW	0 - 600V	5 - 600V	0 ± 200A	2	-30mΩ to 3000mΩ	-30mΩ to 300mΩ
LAB-MOBI 600-160-600-2	160kW	0 - 600V	5 - 600V	0 ± 600A	2	-10mΩ to 1000mΩ	-10mΩ to 100mΩ
LAB-MOBI 600-160-1000-2	160kW	0 - 600V	5 - 600V	0 ± 1000A	2	-6mΩ to 600mΩ	-6mΩ to 60mΩ
LAB-MOBI 800-160-200-2	160kW	0 - 800V	5 - 800V	0 ± 200A	2	-40mΩ to 4000mΩ	-40mΩ to 400mΩ
LAB-MOBI 800-160-600-2	160kW	0 - 800V	5 - 800V	0 ± 600A	2	-13mΩ to 1333mΩ	-13mΩ to 133mΩ
LAB-MOBI 1000-160-200-2	160kW	0 - 1000V	5 - 1000V	0 ± 200A	2	-50mΩ to 5000mΩ	-50mΩ to 500mΩ
LAB-MOBI 1000-160-600-2	160kW	0 - 1000V	5 - 1000V	0 ± 600A	2	-17mΩ to 1667mΩ	-17mΩ to 167mΩ
250kW MODELS							
LAB-MOBI 600-250-200-2	250kW	0 - 600V	5 - 600V	0 ± 200A	2	-30mΩ to 3000mΩ	-30mΩ to 300mΩ
LAB-MOBI 600-250-600-2	250kW	0 - 600V	5 - 600V	0 ± 600A	2	-10mΩ to 1000mΩ	-10mΩ to 100mΩ
LAB-MOBI 600-250-1000-2	250kW	0 - 600V	5 - 600V	0 ± 1000A	2	-6mΩ to 600mΩ	-6mΩ to 60mΩ
LAB-MOBI 800-250-200-2	250kW	0 - 800V	5 - 800V	0 ± 200A	2	-40mΩ to 4000mΩ	-40mΩ to 400mΩ
LAB-MOBI 800-250-600-2	250kW	0 - 800V	5 - 800V	0 ± 600A	2	-13mΩ to 1333mΩ	-13mΩ to 133mΩ
LAB-MOBI 800-250-1000-2	250kW	0 - 800V	5 - 800V	0 ± 1000A	2	-8mΩ to 800mΩ	-8mΩ to 80mΩ
LAB-MOBI 1000-250-200-2	250kW	0 - 1000V	5 - 1000V	0 ± 200A	2	-50mΩ to 5000mΩ	-50mΩ to 500mΩ
LAB-MOBI 1000-250-600-2	250kW	0 - 1000V	5 - 1000V	0 ± 600A	2	-17mΩ to 1667mΩ	-17mΩ to 167mΩ
LAB-MOBI 1000-250-1000-2	250kW	0 - 1000V	5 - 1000V	0 ± 1000A	2	-10mΩ to 1000mΩ	-10mΩ to 100mΩ
320kW MODELS							
LAB-MOBI 600-320-600-2	320kW	0 - 600V	5 - 600V	0 ± 600A	2	-10mΩ to 1000mΩ	-10mΩ to 100mΩ
LAB-MOBI 600-320-1000-2	320kW	0 - 600V	5 - 600V	0 ± 1000A	2	-6mΩ to 600mΩ	-6mΩ to 60mΩ
LAB-MOBI 800-320-200-2	320kW	0 - 800V	5 - 800V	0 ± 200A	2	-40mΩ to 4000mΩ	-40mΩ to 400mΩ
LAB-MOBI 800-320-600-2	320kW	0 - 800V	5 - 800V	0 ± 600A	2	-13mΩ to 1333mΩ	-13mΩ to 133mΩ
LAB-MOBI 800-320-1000-2	320kW	0 - 800V	5 - 800V	0 ± 1000A	2	-8mΩ to 800mΩ	-8mΩ to 80mΩ
LAB-MOBI 1000-320-200-2	320kW	0 - 1000V	5 - 1000V	0 ± 200A	2	-50mΩ to 5000mΩ	-50mΩ to 500mΩ
LAB-MOBI 1000-320-600-2	320kW	0 - 1000V	5 - 1000V	0 ± 600A	2	-17mΩ to 1667mΩ	-17mΩ to 167mΩ
LAB-MOBI 1000-320-1000-2	320kW	0 - 1000V	5 - 1000V	0 ± 1000A	2	-10mΩ to 1000mΩ	-10mΩ to 100mΩ
400kW MODELS							
LAB-MOBI 600-400-600-2	400kW	0 - 600V	5 - 600V	0 ± 600A	2	-10mΩ to 1000mΩ	-10mΩ to 100mΩ
LAB-MOBI 600-400-1000-2	400kW	0 - 600V	5 - 600V	0 ± 1000A	2	-6mΩ to 600mΩ	-6mΩ to 60mΩ
LAB-MOBI 800-400-600-2	400kW	0 - 800V	5 - 800V	0 ± 600A	2	-13mΩ to 1333mΩ	-13mΩ to 133mΩ
LAB-MOBI 800-400-1000-2	400kW	0 - 800V	5 - 800V	0 ± 1000A	2	-8mΩ to 800mΩ	-8mΩ to 80mΩ
LAB-MOBI 1000-400-200-2	400kW	0 - 1000V	5 - 1000V	0 ± 200A	2	-50mΩ to 5000mΩ	-50mΩ to 500mΩ
LAB-MOBI 1000-400-600-2	400kW	0 - 1000V	5 - 1000V	0 ± 600A	2	-17mΩ to 1667mΩ	-17mΩ to 167mΩ
LAB-MOBI 1000-400-1000-2	400kW	0 - 1000V	5 - 1000V	0 ± 1000A	2	-10mΩ to 1000mΩ	-10mΩ to 100mΩ
500kW MODELS							
LAB-MOBI 600-500-600-2	500kW	0 - 600V	5 - 600V	0 ± 600A	2	-10mΩ to 1000mΩ	-10mΩ to 100mΩ
LAB-MOBI 600-500-1000-2	500kW	0 - 600V	5 - 600V	0 ± 1000A	2	-6mΩ to 600mΩ	-6mΩ to 60mΩ
LAB-MOBI 800-500-600-2	500kW	0 - 800V	5 - 800V	0 ± 600A	2	-13mΩ to 1333mΩ	-13mΩ to 133mΩ
LAB-MOBI 800-500-1000-2	500kW	0 - 800V	5 - 800V	0 ± 1000A	2	-8mΩ to 800mΩ	-8mΩ to 80mΩ
LAB-MOBI 1000-500-600-2	500kW	0 - 1000V	5 - 1000V	0 ± 600A	2	-17mΩ to 1667mΩ	-17mΩ to 167mΩ
LAB-MOBI 1000-500-1000-2	500kW	0 - 1000V	5 - 1000V	0 ± 1000A	2	-10mΩ to 1000mΩ	-10mΩ to 100mΩ
650kW MODELS							
LAB-MOBI 1000-650-600-2	650kW	0 - 1000V	5 - 1000V	0 ± 600A	2	-17mΩ to 1667mΩ	-17mΩ to 167mΩ
LAB-MOBI 1000-650-1000-2	650kW	0 - 1000V	5 - 1000V	0 ± 1000A	2	-10mΩ to 1000mΩ	-10mΩ to 100mΩ

¹ The max. current that can be sunk derates as the voltage reduces below 5V. ² The sum total power provided by each channel can't exceed the total system power.

FOUR CHANNEL MODEL SELECTION TABLE

Part Number	Max. Power	Q1 Source Voltage Range	Q4 Sink Voltage Range ¹	Current Range per Channel ²	Number of Channels	Internal Resistance Range - Single Channel	Internal Resistance Range - Channels Paralleled ³
60kW MODELS							
LAB-MOBI 300-60-200-4	60kW	0 - 300V	5 - 300V	0 ± 200A	4	-15mΩ to 1500mΩ	-15mΩ to 150mΩ
LAB-MOBI 600-60-200-4	60kW	0 - 600V	5 - 600V	0 ± 200A	4	-30mΩ to 3000mΩ	-30mΩ to 300mΩ
100kW MODELS							
LAB-MOBI 600-100-200-4	100kW	0 - 600V	5 - 600V	0 ± 200A	4	-30mΩ to 3000mΩ	-30mΩ to 300mΩ
LAB-MOBI 800-100-200-4	100kW	0 - 800V	5 - 800V	0 ± 200A	4	-40mΩ to 4000mΩ	-40mΩ to 400mΩ
LAB-MOBI 1000-100-200-4	100kW	0 - 1000V	5 - 1000V	0 ± 200A	4	-50mΩ to 5000mΩ	-50mΩ to 500mΩ
120kW MODELS							
LAB-MOBI 300-120-200-4	120kW	0 - 300V	5 - 300V	0 ± 200A	4	-15mΩ to 1500mΩ	-15mΩ to 150mΩ
LAB-MOBI 300-120-600-4	120kW	0 - 300V	5 - 300V	0 ± 600A	4	-5mΩ to 500mΩ	-5mΩ to 50mΩ
160kW MODELS							
LAB-MOBI 300-160-200-4	160kW	0 - 300V	5 - 300V	0 ± 200A	4	-15mΩ to 1500mΩ	-15mΩ to 150mΩ
LAB-MOBI 300-160-600-4	160kW	0 - 300V	5 - 300V	0 ± 600A	4	-5mΩ to 500mΩ	-5mΩ to 50mΩ
LAB-MOBI 300-160-1000-4	160kW	0 - 300V	5 - 300V	0 ± 1000A	4	-3mΩ to 300mΩ	-3mΩ to 30mΩ
LAB-MOBI 600-160-200-4	160kW	0 - 600V	5 - 600V	0 ± 200A	4	-30mΩ to 3000mΩ	-30mΩ to 300mΩ
LAB-MOBI 800-160-200-4	160kW	0 - 800V	5 - 800V	0 ± 200A	4	-40mΩ to 4000mΩ	-40mΩ to 400mΩ
LAB-MOBI 1000-160-200-4	160kW	0 - 1000V	5 - 1000V	0 ± 200A	4	-50mΩ to 5000mΩ	-50mΩ to 500mΩ
250kW MODELS							
LAB-MOBI 600-250-200-4	250kW	0 - 600V	5 - 600V	0 ± 200A	4	-30mΩ to 3000mΩ	-30mΩ to 300mΩ
LAB-MOBI 600-250-600-4	250kW	0 - 600V	5 - 600V	0 ± 600A	4	-10mΩ to 1000mΩ	-10mΩ to 100mΩ
LAB-MOBI 800-250-200-4	250kW	0 - 800V	5 - 800V	0 ± 200A	4	-40mΩ to 4000mΩ	-40mΩ to 400mΩ
LAB-MOBI 800-250-600-4	250kW	0 - 800V	5 - 800V	0 ± 600A	4	-13mΩ to 1333mΩ	-13mΩ to 133mΩ
LAB-MOBI 1000-250-200-4	250kW	0 - 1000V	5 - 1000V	0 ± 200A	4	-50mΩ to 5000mΩ	-50mΩ to 500mΩ
320kW MODELS							
LAB-MOBI 600-320-200-4	320kW	0 - 600V	5 - 600V	0 ± 200A	4	-30mΩ to 3000mΩ	-30mΩ to 300mΩ
LAB-MOBI 600-320-600-4	320kW	0 - 600V	5 - 600V	0 ± 600A	4	-10mΩ to 1000mΩ	-10mΩ to 100mΩ
LAB-MOBI 600-320-1000-4	320kW	0 - 600V	5 - 600V	0 ± 1000A	4	-6mΩ to 600mΩ	-6mΩ to 60mΩ
LAB-MOBI 800-320-200-4	320kW	0 - 800V	5 - 800V	0 ± 200A	4	-40mΩ to 4000mΩ	-40mΩ to 400mΩ
LAB-MOBI 800-320-600-4	320kW	0 - 800V	5 - 800V	0 ± 600A	4	-13mΩ to 1333mΩ	-13mΩ to 133mΩ
LAB-MOBI 1000-320-200-4	320kW	0 - 1000V	5 - 1000V	0 ± 200A	4	-50mΩ to 5000mΩ	-50mΩ to 500mΩ
LAB-MOBI 1000-320-600-4	320kW	0 - 1000V	5 - 1000V	0 ± 600A	4	-17mΩ to 1667mΩ	-17mΩ to 167mΩ
400kW MODELS							
LAB-MOBI 600-400-200-4	400kW	0 - 600V	5 - 600V	0 ± 200A	4	-30mΩ to 3000mΩ	-30mΩ to 300mΩ
LAB-MOBI 600-400-600-4	400kW	0 - 600V	5 - 600V	0 ± 600A	4	-10mΩ to 1000mΩ	-10mΩ to 100mΩ
LAB-MOBI 600-400-1000-4	400kW	0 - 600V	5 - 600V	0 ± 1000A	4	-6mΩ to 600mΩ	-6mΩ to 60mΩ
LAB-MOBI 800-400-200-4	400kW	0 - 800V	5 - 800V	0 ± 200A	4	-40mΩ to 4000mΩ	-40mΩ to 400mΩ
LAB-MOBI 800-400-600-4	400kW	0 - 800V	5 - 800V	0 ± 600A	4	-13mΩ to 1333mΩ	-13mΩ to 133mΩ
LAB-MOBI 800-400-1000-4	400kW	0 - 800V	5 - 800V	0 ± 1000A	4	-8mΩ to 800mΩ	-8mΩ to 80mΩ
LAB-MOBI 1000-400-200-4	400kW	0 - 1000V	5 - 1000V	0 ± 200A	4	-50mΩ to 5000mΩ	-50mΩ to 500mΩ
LAB-MOBI 1000-400-600-4	400kW	0 - 1000V	5 - 1000V	0 ± 600A	4	-17mΩ to 1667mΩ	-17mΩ to 167mΩ
500kW MODELS							
LAB-MOBI 600-500-200-4	500kW	0 - 600V	5 - 600V	0 ± 200A	4	-30mΩ to 3000mΩ	-30mΩ to 300mΩ
LAB-MOBI 600-500-600-4	500kW	0 - 600V	5 - 600V	0 ± 600A	4	-10mΩ to 1000mΩ	-10mΩ to 100mΩ
LAB-MOBI 600-500-1000-4	500kW	0 - 600V	5 - 600V	0 ± 1000A	4	-6mΩ to 600mΩ	-6mΩ to 60mΩ
LAB-MOBI 800-500-200-4	500kW	0 - 800V	5 - 800V	0 ± 200A	4	-40mΩ to 4000mΩ	-40mΩ to 400mΩ
LAB-MOBI 800-500-600-4	500kW	0 - 800V	5 - 800V	0 ± 600A	4	-13mΩ to 1333mΩ	-13mΩ to 133mΩ
LAB-MOBI 800-500-1000-4	500kW	0 - 800V	5 - 800V	0 ± 1000A	4	-8mΩ to 800mΩ	-8mΩ to 80mΩ
LAB-MOBI 1000-500-200-4	500kW	0 - 1000V	5 - 1000V	0 ± 200A	4	-50mΩ to 5000mΩ	-50mΩ to 500mΩ
LAB-MOBI 1000-500-600-4	500kW	0 - 1000V	5 - 1000V	0 ± 600A	4	-17mΩ to 1667mΩ	-17mΩ to 167mΩ
LAB-MOBI 1000-500-1000-4	500kW	0 - 1000V	5 - 1000V	0 ± 1000A	4	-10mΩ to 1000mΩ	-10mΩ to 100mΩ
650kW MODELS							
LAB-MOBI 1000-650-200-4	650kW	0 - 1000V	5 - 1000V	0 ± 200A	4	-50mΩ to 5000mΩ	-50mΩ to 500mΩ
LAB-MOBI 1000-650-600-4	650kW	0 - 1000V	5 - 1000V	0 ± 600A	4	-17mΩ to 1667mΩ	-17mΩ to 167mΩ
LAB-MOBI 1000-650-1000-4	650kW	0 - 1000V	5 - 1000V	0 ± 1000A	4	-10mΩ to 1000mΩ	-10mΩ to 100mΩ

¹ The max. current that can be sunk derates as the voltage reduces below 5V. ² The sum total power provided by each channel can't exceed the total system power.

³ Values are applicable to both combinations of either 2 channel in parallel connection or 4 channels in parallel connection.

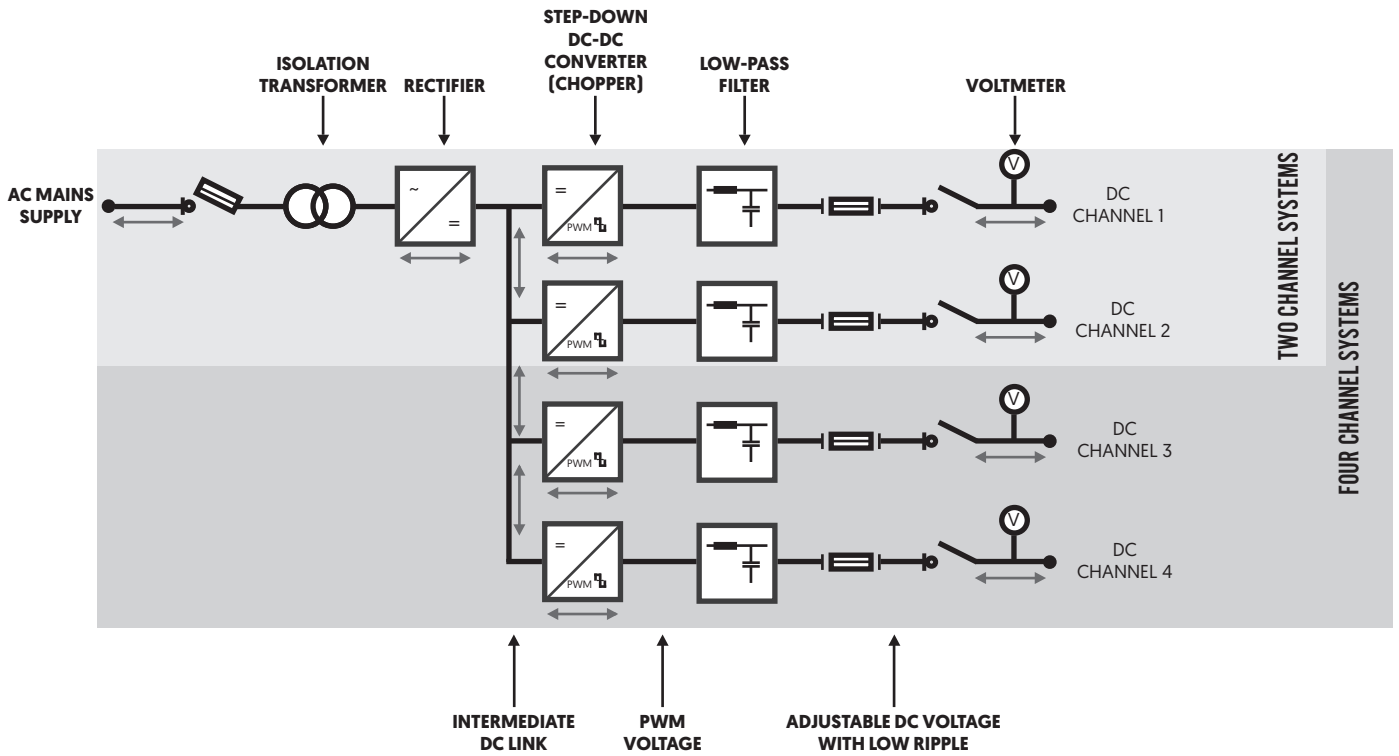

INPUT

STANDARD FEATURES

TECHNICAL DATA

Rectifier Type	Isolation transformer, galvanically isolated
Power Factor	>0.99 (at >55% load), >0.83 (at 10% load)
AC Input Voltage/Frequency	400V ¹ ± 10%, 3-phase, (N), PE, 50 / 60Hz ± 5%

¹ 380V, 415V, 420V, 440 and 480V inputs are available on request.

HIGHLIGHTED FEATURE



ACTIVE POWER FACTOR CORRECTION

LAB-MOBI systems have Active Power Factor Correction (PFC) circuit integrated into the input stage as standard. This enhances the overall efficiency of the systems across the output power range when compared to a unit that does not have active PFC. In practice, this means a significant lower peak current value, a decrease of RMS value of the phase current and less perturbations of other equipment running on the same grid.

Cos Phi as a function of DC Output Voltage and Power

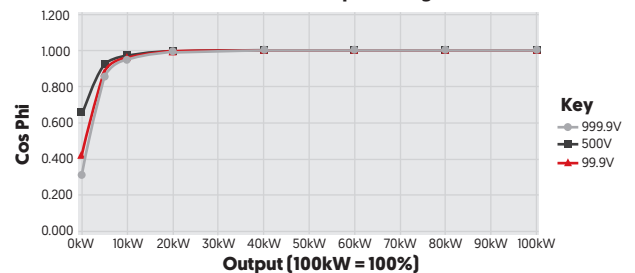

OPTIONS

CODE	DESCRIPTION
/NSV	Non standard AC input voltage (eg. 690Vac).

GENERAL SPECIFICATIONS

STANDARD FEATURES

TECHNICAL DATA	
Permissible Ambient Temperature	0 - 40°C
Climate Class	3K3 EN60721 [85% relative humidity non condensing, with cabinet heating up to 95% relative humidity without condensing]
Cooling	Forced air cooling / air-water heat exchanger
Minimum Distance from Wall	0mm [standard] for rear and side
Minimum Distance from Ceiling	300mm [standard], 0mm possible [optional]
Installation	Operating area with restricted access
Protection Class	IP20 [as standard] IEC 60529
Maximum Altitude	1000m above sea level with nominal load

HIGHLIGHTED FEATURES

IP20 CABINETS

As standard, each LAB-MOBI cabinet is rated to IP20. The base of each cabinet has slots in it so it can be easily moved around via pump trucks or forklifts. Cable entry is also provided via the bottom of the cabinet. The standard front to top airflow cooling system means that no distance between the wall and rear of the cabinet is required.

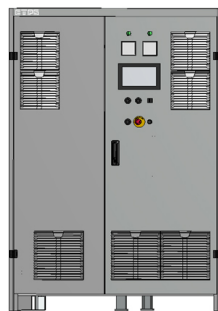

POWER RECYCLING

When functioning as a load, the LAB-MOBI has an inbuilt monitoring system that synchronises with grid conditions. This recycles DC sink energy back to the grid, with typical losses of only 5-10%.

LONG LIFE COMPONENTS

Each LAB-MOBI system is built for longevity. The lowest life components being the fans rated at 67,000h and electrolytic capacitors rated at 130,000h/15 years. This ensures that the systems are suitable for constant operation in long term projects.

OPTIONS

CODE	DESCRIPTION
/IP21	Additional roof structure providing protection to IP21. Height increases by 300mm. Rear of cabinets can be positioned against walls.
/IP23	Top mounted fans providing protection to IP23 cabinet. Height increases by 300mm. Rear of cabinets can be positioned against walls.
/IP54-TOP	Top Mounted air to liquid heat exchangers. Cabinet heights increase to 2750mm, depths increase to 900mm. Rear of cabinets can be positioned against walls.
/IP54-REAR	Top Mounted air to liquid heat exchangers. Cabinet depths increase to 1160mm. Additional clearance of 800mm recommended at the rear for service/maintenance.
/CAB-HALOGEN-FREE	Each cabinet is fitted with halogen free cables.
/CAB-HEATING-SEP	100W heating element at the bottom of the cabinet to help guard against condensation.
/CAB-BAS-200	Additional 200mm base plinth, providing a larger possible bend radius for ease of cable access. 200mm is added to the standard cabinet height.
/SIGNAL-WHITE	All cabinets are painted in Signal White [RAL 9003].
/CUSTOM-RAL	All cabinets are painted in a user chosen RAL colour.

ILLUSTRATED OPTIONS

Other cabinet IP ratings are available on request. Please contact ETPS with your specific requirement.

SIGNAL WHITE

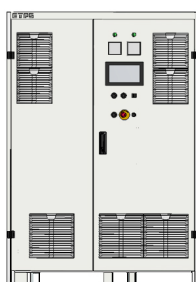

IP21

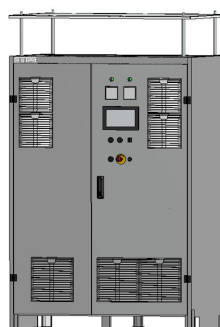

IP23

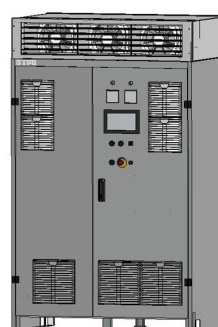

IP54-TOP

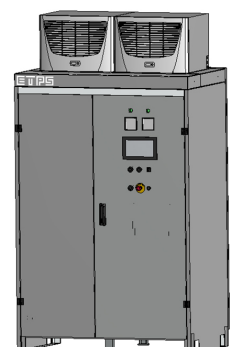

STANDARD FEATURES

TECHNICAL DATA	
2 Channel Operating Modes	1. CH1 & CH2 in single operation; 2. CH1 & CH2 in parallel operation
4 Channel Operating Modes	1. CH1, CH2, CH3 & CH4 in single operation; 2. CH1 & CH2 in parallel operation, CH3 & CH4 in single operation; 3. CH1 & CH2 in parallel operation, CH3 & CH4 in parallel operation; 4. CH1, CH2, CH3 & CH4 in parallel operation
Maximum Output Voltage	See selection table
Minimum Output Voltage	5V (typical) to sink full current within the maximum power capability
Measuring Accuracy and Resolution	Voltage: 0.1% F.S. / 16 bit ADC, current: 0.1% F.S. / 16 bit ADC
Control Accuracy ^{2,3}	Voltage: 0.1% F.S. , current: 0.1% F.S.
Voltage Tolerance Dynamic	Battery simulator mode: <1% F.S. [0 - 100% I _{NOM} in 3ms], Battery tester mode: <3% F.S. [0 - 100% I _{NOM} in 3ms]
Voltage Ripple ⁴	≤0.1% rms F.S. [V > 10]
Current Ripple ⁵	≤0.1% rms F.S. [V > 10]
Current Rise Time ⁶	See selection table
Overall Efficiency	Typically 92% to 95% (depending on system power)

² Via 16 bit digital controller. ³ Digital controller (± 600A = 15 bit + sign). ⁴ Resistance as load, operation mode simulator (in constant voltage mode).

⁵ 48/96V battery (constant voltage mode). ⁶ Measured at half nominal voltage with max. 5% overshoot (in constant current mode).

HIGHLIGHTED FEATURES

FAST DYNAMICS AND HIGH STABILITY

The LAB-MOBI provides a highly stable output of ≤0.1% rms F.S. for both current and voltage, ideal for powering sensitive DUTs. The high dynamics of the system allows users to switch quickly between quadrants. This is particularly useful when performing tests on bidirectional devices with fast current step changes such as super capacitors and electric motors. A typical time for a 10% to 90% load step in CC mode is less than 1ms assuming an ohmic load. Example scope shots of a previous test are provided below:

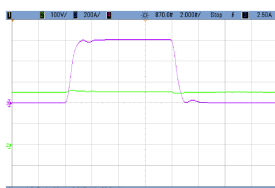

Measurement in Source Mode
 Current step: 10 to 90% (60 to 540A)
 Output filter: 1200µF
 Measured value: 0.8ms

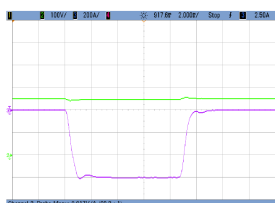

Measurement in Sink Mode
 Current step: -10 to -90% [-540 to -60A]
 Output filter: 1200µF
 Measured value: 0.8ms

SENSE COMPENSATION

Sense terminals are built into the LAB-MOBI for the connection of sense wire which compensates for voltage drops in the load lines. Up to 5% of the system's nominal voltage value can be compensated for. This is particularly useful for applications with long cables which have unwanted voltage drops.

SEAMLESS SOURCE/SINK TRANSITION

When switching between sinking and sourcing current, the LAB-MOBI provides a seamless transition. This means that during the quadrant change there is zero deadband time and no unwanted/disruptive behaviour is introduced to the power system's output characteristics. This feature is particularly useful for when users need to switch between charging and discharging a battery at a constant current rate, or simulate fast dynamics.

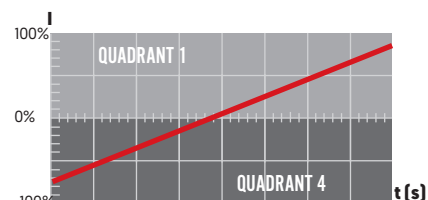

LAB-MOBI seamless transition between sink and source

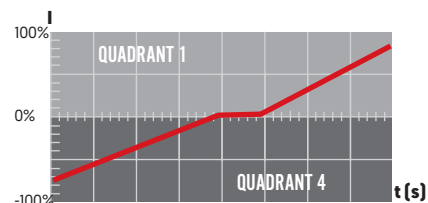

Typical bidirectional power system without seamless transition

INTERNAL RESISTANCE RANGE

Each LAB-MOBI is built with a user programmable internal resistance range as standard. This makes the power systems ideal for simulating the output of energy storage devices such as an ageing battery pack, fuel cell stacks and super capacitors. The exact range varies by model, for model specific details please contact ETPS.

OUTPUT

OPTIONS

CODE	DESCRIPTION
/SCR	Second current range for improved resolution and accuracy in low current applications (not available with option /ANALOGUE-IPLUS).
/B-CAP-M	External IP66 metal control cabinet with switchable output capacitors. 20360µF of additional capacitance is provided for models up to 800V, with 9660µF available for 1000V systems. Special 1100V metal capacitor boxes with discharge resistors are available on request.
/B-CAP-P	External IP66 plastic control cabinet with switchable output capacitors. 19800µF of additional capacitance is provided for models up to 800V, with 8100µF available for 1000V systems.
/PDSB-1IN-2OUT	External cabinet for switching a single LAB-MOBI channel between 2 separate test cells/DUTs. Cabinet is rated IP20 as standard with IP53 available on request. Dimensions are available on request. Up to 4 discharge units (/DCU-X-XX) can be built into the cabinet.
/PDSB-1IN-4OUT	External cabinet for switching a single LAB-MOBI channel between 4 separate test cells/DUTs. Cabinet is rated IP20 as standard with IP53 available on request. Dimensions are available on request. Up to 4 discharge units (/DCU-X-XX) can be built into the cabinet.
/PDSB-2IN-1OUT	External cabinet for combining 2 x LAB-MOBI channels into a single output. Cabinet is rated IP20 as standard with IP53 available on request. Dimensions are available on request. Up to 4 discharge units (/DCU-X-XX) can be built into the cabinet.
/PDSB-2IN-2OUT	External cabinet for operating 2 x LAB-MOBI channels in parallel, switching the combined output to 1 of 2 test cells. The 2 x LAB-MOBI channels can also be operated individually into the 2 test cells. Cabinet is rated IP20 as standard with IP53 available on request. Dimensions are available on request. Up to 4 discharge units (/DCU-X-XX) can be built into the cabinet.
/PDSB-2IN-4OUT	External cabinet for operating 2 x LAB-SMOBI channels in parallel, switching the combined output to 1 of 4 test cells. The 2 x LAB-MOBI channels can also be operated individually into 2 of 4 test cells. Cabinet is rated IP20 as standard with IP53 available on request. Dimensions are available on request. Up to 4 discharge units (/DCU-X-XX) can be built into the cabinet.
/PDU-TEST	Control cabinet rated to IP54 for local installation close to DUT when operating in Battery Testing mode. Cabinets are available with 1, 2 or 4 inputs at up to 1000V/4000A. Dimensions are available on request. A 1000V voltmeter is included, as is a 4 position light post to signal operational status of the system.
/PDU-SIM	Control cabinet rated to IP54 for local installation close to DUT when operating in Battery Simulation mode. Cabinets are available with 1, 2 or 4 inputs at up to 1000V/4000A. Dimensions are available on request. A 1000V voltmeter is included, as is a 4 position light post to signal operational status of the system. Other features include an installed shorting link and 2 x MXP capacitors 280µF/1120Vdc.
/PDU-SIM-TEST	Control cabinet rated to IP54 for local installation close to DUT when operating in Battery Tester or Battery Simulation mode. Cabinets are available with 1, 2 or 4 inputs at up to 1000V/4000A. Dimensions are available on request. A 1000V voltmeter is included, as is a 4 position light post to signal operational status of the system. 2 x MXP capacitors 280µF/1120Vdc are also installed.
/SENSE-M	Sense cable connecting the LAB-MOBI and the device under test or /PDU-XXX.
/CONTROL-M	Control cable connecting the LAB-MOBI and the /PDU-XXX.

HIGHLIGHTED OPTIONS



POWER DISTRIBUTION UNITS

A PDU is used to connect a LAB-MOBI to a DUT, when the power system is located in a different place. Both wall mounted and free standing cabinets are available. A voltmeter is included, as is an indicator light which shows the status of the insulation monitoring (turned off or active). A short-circuit switch for safe connection of a DUT when operating in quadrant 4 is available for certain models (battery simulator mode only).

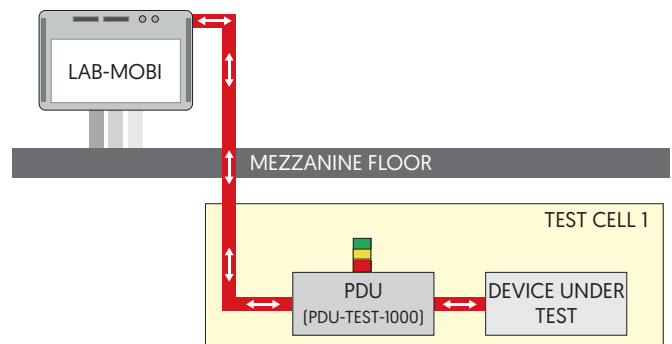

HIGHLIGHTED OPTIONS



POWER DISTRIBUTION SWITCH BOARDS (PDSU)

PDSB control cabinets can be provided for remotely switching the output of a single LAB-MOBI channel between separate test cells, or for connecting the output of two separate LAB-MOBI channels in parallel to a nominated test cell. Up to four discharge units can also be installed in the cabinet on request.

PDSB-1IN-2OUT

PDSB-1IN-2OUT CONFIGURATIONS

Operation Mode	Test Cell 1	Test Cell 2
1	Contactors Open	Contactors Open
2	Channel 1	Contactors Open
3	Contactors Open	Channel 1

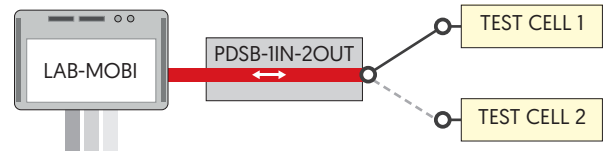

PDSB-1IN-4OUT

PDSB-1IN-4OUT CONFIGURATIONS

Operation Mode	Test Cell 1	Test Cell 2	Test Cell 3	Test Cell 4
1	Contactors Open	Contactors Open	Contactors Open	Contactors Open
2	Channel 1	Contactors Open	Contactors Open	Contactors Open
3	Contactors Open	Channel 1	Contactors Open	Contactors Open
4	Contactors Open	Contactors Open	Channel 1	Contactors Open
5	Contactors Open	Contactors Open	Contactors Open	Channel 1

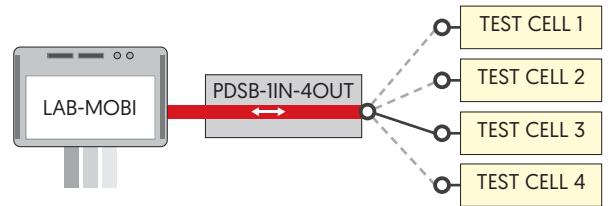

PDSB-2IN-2OUT

PDSB-2IN-2OUT CONFIGURATIONS

Operation Mode	Test Cell 1	Test Cell 2
1	Contactors Open	Contactors Open
2	Channel 1	Channel 2
3	Channels 1 & 2 in Parallel	Contactors Open
4	Contactors Open	Channels 1 & 2 in Parallel

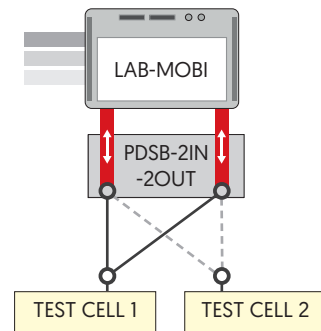

PDSB-2IN-4OUT

PDSB-2IN-4OUT CONFIGURATIONS

Operation Mode	Test Cell 1	Test Cell 2	Test Cell 3	Test Cell 4
1	Contactors Open	Contactors Open	Contactors Open	Contactors Open
2	Channel 1	Channel 2	Contactors Open	Contactors Open
3	Contactors Open	Contactors Open	Channel 1	Channel 2
4	Channels 1 & 2 in Parallel	Contactors Open	Contactors Open	Contactors Open
5	Contactors Open	Channels 1 & 2 in Parallel	Contactors Open	Contactors Open
6	Contactors Open	Contactors Open	Channels 1 & 2 in Parallel	Contactors Open
7	Contactors Open	Contactors Open	Contactors Open	Channels 1 & 2 in Parallel

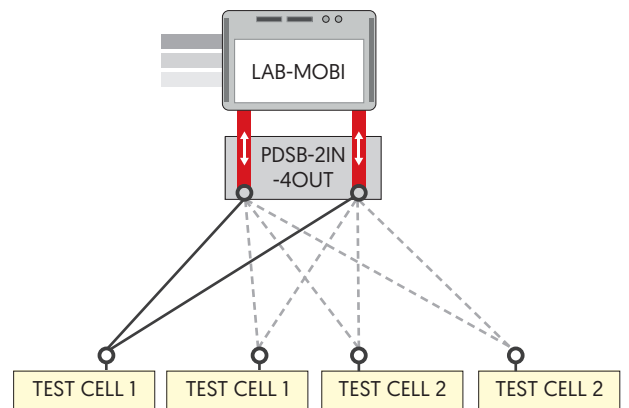

OUTPUT

HIGHLIGHTED OPTIONS

RANGE1 RANGE2 SECOND CURRENT RANGE

A second current range can be built into systems to give better accuracy and resolution for low current applications. This is particularly useful when testing high voltage equipment, such as electric vehicle battery packs, which typically produce low currents. The lower current range is not operable for a configuration of 2 or more LAB-MOBI channels operating in parallel.

CAPACITANCE VALUES

Output capacitance is provided to improve stability when operating in constant voltage mode. This is particularly useful to assist the fast current demands when testing drives. Some electric drives require a very stable voltage during a step change. If the voltage drop is too low it could damage the drive.

When choosing the /SIM-TEST option an extra level of capacitance is provided. If a test routine requires the fastest possible dynamics in constant current mode, then the standard capacitance of the LAB-MOBI can be used in the basic or battery tester operation modes. For people who frequently need to switch between battery tester and simulation modes the /SIM-TEST option is ideal. This provides the ability to change between the lower and higher level of capacitance.

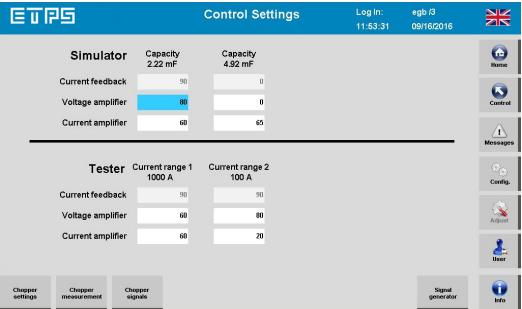

CAPACITANCE BUILT INTO LAB-MOBI SYSTEMS		
	Standard in Basic and Battery Tester Modes	/SIM-TEST Option
300V/600A Models	Installed: 2490µF, Total: 2490µF	Additional: 4400µF, Total: 6890µF
600V/200A Models	Installed: 1660µF, Total: 1660µF	Additional: 6600µF, Total: 8260µF
600V/600A Models	Installed: 1660µF, Total: 1660µF	Additional: 6600µF, Total: 8260µF
600V/1000A Models	Installed: 2490µF, Total: 2490µF	Additional: 6600µF, Total: 9090µF
800V/200A Models	Installed: 1660µF, Total: 1660µF	Additional: 6600µF, Total: 8260µF
800V/600A Models	Installed: 1660µF, Total: 1660µF	Additional: 6600µF, Total: 8260µF
800V/1000A Models	Installed: 1660µF, Total: 1660µF	Additional: 6600µF, Total: 8260µF
1000V/200A Models	Installed: 1660µF, Total: 1660µF	Additional: 2700µF, Total: 4360µF
1000V/600A Models	Installed: 1660µF, Total: 1660µF	Additional: 2700µF, Total: 4360µF
1000V/1000A Models	Installed: 2490µF, Total: 2490µF	Additional: 2700µF, Total: 5190µF

ILLUSTRATED CAPACITANCE OPTIONS

The /B-CAP-X options provide you with additional capacitance from an external box, which can be switched between 3 different levels depending on the requirements of the test application. As a result, users with long load lines can situate the box next to the device under test.



/B-CAP-M

INTERFACES & CONTROL

STANDARD TOUCHSCREEN CONTROL

The LAB-MOBI comes with a simple and intuitive TFT touchscreen with a menu driven interface which allows measuring and setting of V, I, P and Ri values among others. The interface provides users with the convenience of remote access when setting test values. Up to 4 output channels can be controlled through the same user interface, providing users with a central point of programming. The touchscreen is also accessible via a PC through the VNC over Ethernet interface, as mentioned overleaf.

Current and voltage ramps are programmable should you need to replicate a defined output for a specific research application. An under voltage limit can be user set to prevent a deep discharge which could potentially damage a battery pack. An event log is also provided which provides details of user actions, warnings and faults.

Up to 10 named users can be specified to operate the interface, each with their own password. Varying levels of permission access can be assigned to each user, from simple access where it is only possible to view measured values and switch the system on/off, to configurator level where users can control more complex features such as enabling DC contactors to be open/closed or setting ramps and shutdown limits.

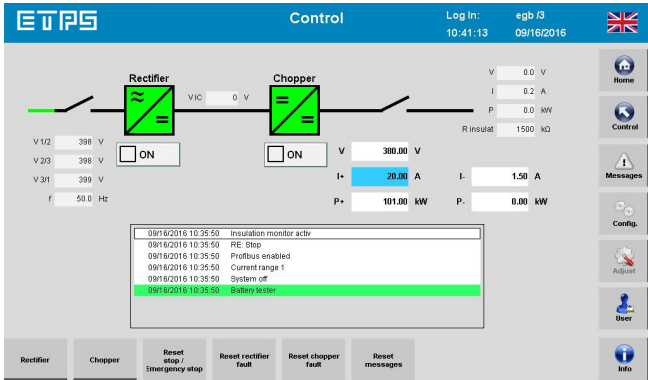
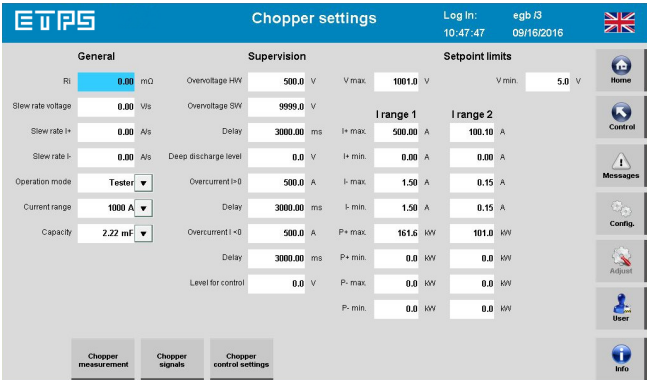

STANDARD OPERATING MODES

Each LAB-MOBI features constant power, constant current, constant power and internal resistance operation. As standard the power system operates in battery testing mode. This is ideal for testing battery power components and provides users with the benefits of:

- + High dynamics during current changes
- + Output filter with lower capacitance
- + Control mode: current (CC)
- + Fast current rise time
- + Current ripple <0.1% f.s. rms at Vdc>10Vdc

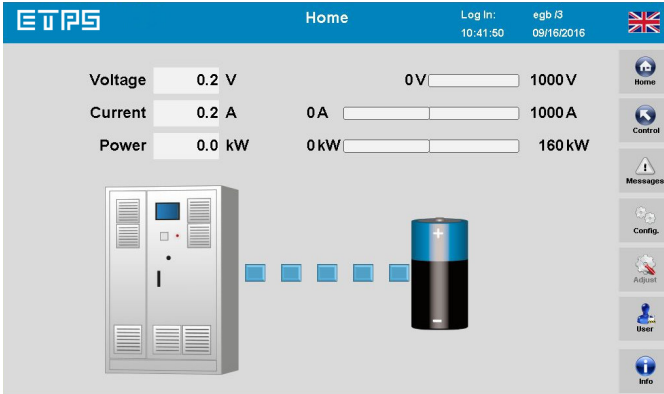

INTERFACES & CONTROL

CAN 2.0 STANDARD INTERFACES

A CAN 2.0 interface with dbc file is provided as standard. This operates at 100Hz. The fast sampling frequency allows users to record quickly changing data, so that they can identify what's happening at a particular point in time. A MODBUS is also provided along with VNC over Ethernet.

HIGHLIGHTED FEATURE

VNC OVER ETHERNET

The VNC over Ethernet interfaces allows the touchscreen to be controlled via a PC. This feature is particularly useful for remote operation where the system may be operating in a potentially hazardous environment, or isolated from the device under test.



OPTIONS

CODE	DESCRIPTION
/SCPI	SCPI interface over Ethernet operating at 100Hz for remote programming.
/PROFIBUS	PROFIBUS DP interface operating at 100Hz for remote programming.
/PROFINET	PROFINET interface for remote programming.
/ANALOGUE	0-10V analogue interface operating at 100Hz for remote programming.
/ANALOGUE-IPLUS	High speed 0-10V analogue interface with access to I+ controller for remote programming. The interface operates at 250Hz (not available with option /SCR).
/ETHERCAT	EtherCAT interface operating at 100Hz for remote programming.
/SIM-TEST	Allows the LAB-MOBI to be switchable between battery testing mode and battery simulation mode.

HIGHLIGHTED OPTION

BATTERY SIMULATION (/SIM-TEST)

Where you require to both test and emulate batteries, the system can be installed with both operating modes (/SIM-TEST), which are user switchable between the two. The battery simulation mode provides users with the benefits of:

- + Low voltage dip during current transients
- + Output filter with higher capacitance
- + Control mode: voltage [CV]

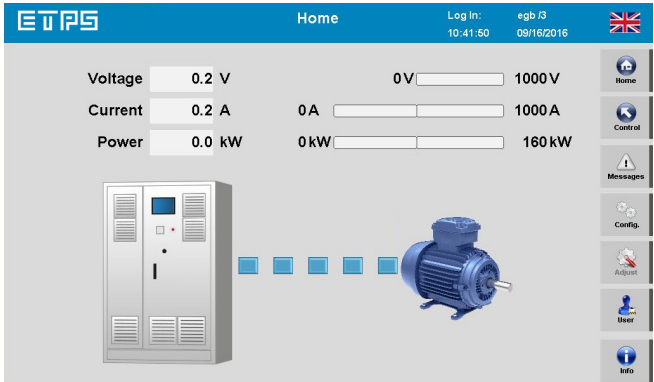

ISOLATION, SAFETY & PROTECTION

STANDARD FEATURES

TECHINICAL DATA	
Isolation (Primary/Secondary)	5.3kVdc
Isolation (Primary/Case)	2.8kVdc
Isolation (Secondary/Case)	2.8kVdc (models $\leq 600\text{Vdc}$), 3.1kVdc (models $> 600\text{Vdc}$)
Short Circuit Behaviour	Short circuit proof ($I_k < 5\text{kA}$)
Protections	Over voltage protection, under voltage protection, over temperature protection, over current protection
Safety	EN ISO 13849-1
Basic Standard	EN 62040
EMC	EN 61000-2-4 grid disturbances, EN 61000-6-2 interference immunity, EN 61000-6-4 interference emission, EN 61800-3 cat C2 (A1) variable - speed electrical drives

HIGHLIGHTED FEATURES

STOP BUTTON

Each channel of the LAB-MOBI is built with a black stop button as standard. This only shuts down a particular channel. For a complete system shutdown of all channels, an emergency stop circuit is provided which meets performance level d according to EN ISO 13849-1. A red emergency stop button is optionally available.

OVP, UVP, OCP & OTP PROTECTION

Over voltage and over current protection limits can be adjusted to help safeguard sensitive loads. An under voltage limit can be also be user set to prevent a deep discharge which could potentially damage a battery pack.

OPTIONS

CODE	DESCRIPTION
/FLOATSAF	2 channel potential free relay board for signalling DC contactors open (safety rated to PLd).
/FLOAT	4 potential free contacts for remote signalling and monitoring of system state (not safety rated).
/DC-1000A-1000V	2 x DC disconnectors rated at 1500V/1000A performance level D.
/DIODE-1000	Diode providing protection up to 1000A/1000V for the device under test. The diode is provided in a wheeled cabinet. Dimensions are available on request. The cabinet comes with a status indication lamp and 2 voltmeters.
/DCU-2-500	Protection unit which discharges energy from a device under test into a resistor when the output of the LAB-MOBI is turned off. Resistance of 2Ω at up to 500kW per second is switched via a thyristor. The discharge unit also functions when the emergency stop is pressed.
/E-STOP	Red emergency stop mushroom button on cabinet door.
/DOOR-STOP	Door fitted interlock. The LAB-MOBI system shuts down when the cabinet door is opened.
/ISOMETER	Isolation monitoring device linked into safety system.

HIGHLIGHTED OPTIONS

BLOCKING DIODE

A blocking diode is available to provide protection for the device under test against any back EMF. This is particularly useful to prevent damage to unidirectional power sources such as fuel cells. The device provides protection up to 1000A and comes in its own wheeled cabinet with 2 voltmeters to measure both sides of the diode assembly.

DC DISCONNECTORS

DC contactors are available that are linked to the safety system as standard. If the emergency stop is triggered the contactors open. They are designed to be operated under load and have an expected lifetime of 10,000 switch cycles under load.

DISCHARGE UNIT

Discharge units are available as an additional safety feature. When the DC output is turned off, energy from the device under test will be discharged into a resistor at up to 500kW per second. This ensures that there is no residual energy on the DC link when disconnecting a device under test. This feature also works when the emergency stop button is pressed.

FEEDING LOSSES IN DYNAMOMETERS

The wide operating ranges of the LAB-MOBI are ideal for operating two dynamometers back to back in a closed circuit, as they feed DC energy into the loop to compensate for losses in the circuit. Rapid response times allow the power supply to react quickly to current demand, which is especially important when testing motorsport vehicles during fast step changes from acceleration and deceleration.

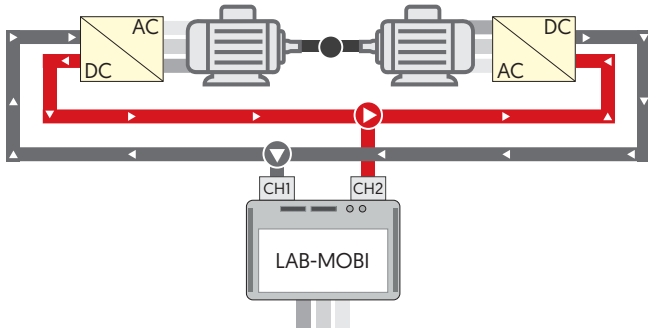

TESTING ELECTRIC DRIVES

LAB-MOBI systems can be optionally built with a high level of output capacitance, to improve stability when operating in constant voltage mode. This is particularly useful to assist the very fast peak demand of current when testing electric drives. Some electric drives are susceptible to damage if the voltage drop is too low, so a stable voltage is often vital to prevent this condition occurring.



TESTING FLYWHEELS

LAB-MOBI power systems are ideal for the production testing of flywheels. The bidirectional nature of each system allows them to actively decelerate the flywheel at the end of testing. This increases efficiency, as the flywheel doesn't have to freely spin and stop before the next one is tested.

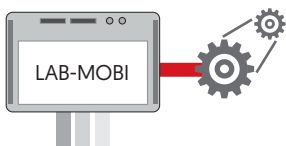

INVERTER/CONVERTER TESTING

The DC input of a power conversion device can be replicated. The influence that variables, such as line voltage variation, have on performance can be isolated and tested. This allows optimum operating conditions to be characterised to improve efficiency and performance.

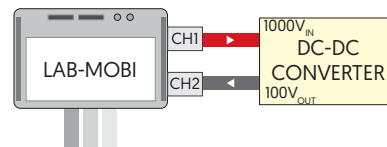

COMPONENT LIFETIME TESTING

The LAB-MOBI can create operating conditions which electrical systems will be subjected to in real world use. By using a computer interface, an automated test routine can be written and repeated on a controlled loop. Potential degradation issues later in the products lifetime can be identified and rectified. Quality testing can also be performed, to ensure that components are working as expected before they leave the manufacturing facility.

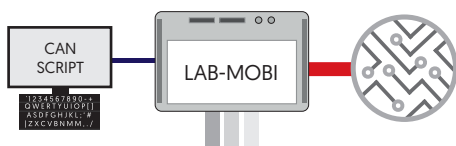

FUEL CELL LOADING

When used as an electronic load, the LAB-MOBI replaces fuel cell powered components, emulating user discharge behaviour. When load testing, the LAB-MOBI recycles sink energy back to the local grid. This allows companies to use the energy produced from their own fuel cells during testing, to power other on-site equipment.

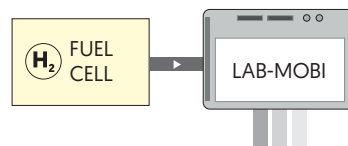

Every effort is made to ensure that the information provided within this technical summary is accurate. However, ETPS Ltd must reserve the right to make changes to the published specifications without prior notice. Where certain operating parameters are critical for your application we advise that they be confirmed at the time of order. ETPS Ltd specialises in modifying its proven platforms to suit your needs. Please contact our office if your requirement is non-standard. Please note that your actual unit may differ from those shown.



“
**WE ARE
POSITIVE
PEOPLE**
”

ETPS engineer electronic power supply and testing systems. Our problem solving skills provide the spark of innovation to some of the world's leading technology brands.



Tel: +44 (0) 1246 452909
Sales: 0800 612 95 75
sales@etps.co.uk
www.etps.co.uk

ETPS Ltd
Unit 14, The Bridge
Beresford Way, Chesterfield
S41 9FG



POSITIVE PROBLEM SOLVING